

Word of Hope

MOUNT HOPE
United Methodist Church



Pastor McGill Writes. . .

Overcoming Offense

The writer of Proverbs gives us insight into the destructive power of taking up an offense. He writes, "An offended brother is more unyielding than a fortified city, and disputes are like the barred gates of a citadel." (Proverbs 18:19 NIV).

John Mason, motivational speaker and author, once said, "Living a life of unforgiveness is like leaving the parking brake on when you drive your car. It causes you to slow down and lose your momentum."

Unforgiveness affects many Christians' lives, keeping them from receiving God's best. When something doesn't go our way, or someone says or does something to hurt us, there is something we can do besides get offended. We can choose to forgive.

What does it mean to be offended? In the dictionary, the word "offend" means to displease, make angry, vex, annoy, and insult. Strong's Exhaustive Concordance of the Bible defines the word "offend" as to scandalize, entrap, trip up, stumble, and entice to sin.

There are many reasons why people become

offended. Often the root of offense is jealousy. For instance, if a person is in line for a promotion on his job, and someone else gets promoted instead, he might become offended because he is jealous of that other person. But he is forgetting that God has an abundant supply for everyone.

Often people take offence by focusing on a wrong done to them. Someone may wrong you, but you don't have to let it offend you. The more you think about the wrong, the worse it gets. The more it is on your mind, the more you will pull away from the things of God and the will of God for your life.

The Bible says, "...Your enemy the devil prowls around like a roaring lion looking for someone to devour." (1 Peter 5:18) If satan can get you to be offended by your fellow Christian, he has half devoured you already! You'll do the rest yourself by allowing that offense to eat at you and separate you from the things of God.

Taking offense will keep you from receiving the best from God and His Word. It will rob you of the good

things in life. Keeping you offended is a strategy of satan to get you out of the will of God. You can't accomplish the will of God when you're offended and holding unforgiveness against your fellow Christian.

Being offended will cause you to experience unnecessary suffering. When you allow resentment to get hold of you, you're going to travel a road that you really don't want to travel. You're going to end up in life somewhere you really don't want to be! And you're going to pay a higher price than you ever thought possible.

Taking offence will hinder your creativity and your ability to perform, because it begins to consume you and your thinking. It will hinder your progress and your opportunity for promotion.

Being offended will affect you spiritually, mentally, emotionally, and physically. If someone offends you, just make up your mind to forgive him!

Taking offense can and will destroy you. Living with God and refusing to

(continued on Page 5)

November 2010

Inside this issue:

<i>Our Church Family</i>	2
<i>November Worship</i>	
<i>Thanksgiving Cornucopia</i>	
<i>Sound Board</i>	
<i>Kid's Choir</i>	
<i>Prayer Shawls</i>	
<i>Christmas Cantata</i>	3
<i>Op. Christmas Child</i>	4
<i>Children's Center News</i>	
<i>Notable Quotes</i>	
<i>Youth Page</i>	Insert
<i>Overcoming Offense</i>	5
<i>Kids' Page</i>	6
<i>Calendar</i>	7
<i>Feast of Thanksgiving</i>	8

Special points of interest:

- ◆ **2nd: Election Day –VOTE! Baptism Seminar**
- ◆ **4th: Charge Conference**
- ◆ **8th: HIS Ministry**
- ◆ **7th: All Saints Sunday; Veterans' Recognition**
- ◆ **11th: Veterans Day**
- ◆ **13th: HIS Ministry**
- ◆ **14th: Communion; Op. Christmas Child deadline**
- ◆ **20th: Scout Food Drive**
- ◆ **21st: Harvest Home; Community TG service**
- ◆ **25th: Happy Thanksgiving!**
- ◆ **28th: First Sunday, Advent**



BAPTISM

September 26, 2010
Jack Thomas Dolly, son of Patrick and Eileen Dolly
Morgan Faye O'Rourke

WEDDINGS

Dorothy Silva and Christopher Accor, September 2, 2010
Amanda Neary and David Meehan, September 18, 2010

DEATH

Lila J. Clinger, October 10, 2010

Where's Heaven?

The Rev. Billy Graham tells of a time early in his career when he arrived in a small town to preach a sermon. Wanting to mail a letter, he asked a young boy where the post office was.

When the boy told him, Rev. Graham thanked him and said, "If you'll come to the Baptist church this evening, you can hear me telling everyone how to get to Heaven."

"I don't think I'll be there," the boy replied. "You don't even know your way to the post office."

Mount Hope Church Staff

- Rev. Dr. Thomas C. McGill, Senior Pastor
- Rev. George S. Rigby, Jr., Pastor of Visitation
- Pastor Philip G. Ealy, Family Life Ministry
- Cynthia Babiak, Youth Director
- Kristine Leary, Director, Children's Center
- Sharon Kope, Director of Music
- Donna Kelly, 9:30 Worship Coordinator
- Eileen McIntyre, Handbell Director
- Larry Bakey, Cemetery Director
- Lin Heintz, Secretary
- Joan Bear, Asst. Secretary
- Leo Volmer, Building Superintendent
- Larry Miles, Asst. Bldg. Superintendent
- Bud Bostwick, Security Guard

November Worship

The Lord has been revealing things to me about putting my house in order. As I share them with you on Sundays, I trust they will be a blessing to you in putting your house in order, too.

November 7th: All Saints Sunday and Veteran's Recognition.

Message: *"Truthfully Assessing Your Situation"*

Scripture: Philippians 3: 12-14

November 14th: Communion. Message: *"The Devil's Destination"*

Scripture: Ephesians 6:1-13

November 21st: Thanksgiving Sunday. Message: *"High-Class Service with Distinction and Style"*

Scripture: Mark 10: 35-45

November 28th: First Sunday in Advent, Pastor Rigby preaching.

Pastor McGill

A Thanksgiving Cornucopia

"Each man should give what he has decided in his heart to give, not reluctantly or under compulsion, for God loves a cheerful giver." 2 Corinthians 9:7

A cornucopia is a symbol of food and abundance. Also referred to as a Horn of Plenty, it is a horn-shaped basket filled with various

kinds of festive fruits and vegetables. In North America, the cornucopia has come to be associated with Thanksgiving and the harvest.

Last year we placed a big cornucopia on the communion table to display the canned and boxed items we collected during the month of November for the Thanksgiving

baskets that we give to families in need. I believe everyone was amazed at how much food we collected to be shared with others.

I look forward to watching the food "pour" in this year and we can gather even more than last year! Bring your donations by Harvest Home Sunday, November 21st.

Sharon Kope

Sound Board Operators

Do you have an interest in serving the Lord but just do not know how? We have heard your call and can definitely use your ear!!! We are looking

for more soundboard operators to run the soundboard and/or slides for each of our three services. If you would like to help out at least once a month during the service you

attend, please contact Donna Kelly, 610-494-3359. You will have training prior to being scheduled.

Kids' Choir

In case you missed our notice in the October newsletter, a new Children's Choir has begun and YOUR child is invited to partici-

pate. Our choir meets on Sunday mornings from 11:00 -11:30 AM in the Junior Church room (Room 101 next to the Nursery). Come

join us and praise the Lord in song! For more information, contact Donna Kelly, 610-494-3359 or dkelly@nemours.org.

Prayer Shawl Ministry

Thank you so much for your response to the Prayer Shawl Ministry during the worship service on October 3rd. We prayed over 23 shawls and scarves and just about all have been distributed to people in need! Some people wanted the prayer bands because they are something you can wear all the time. God is definitely mov-

ing in this ministry. Praise the Lord!

We also received some contributions toward purchasing yarn. Thank you, everyone! Continue to keep your ears and eyes open for those who would benefit from a scarf or shawl, and pray for those who have received prayer shawls and scarves.

We're grateful, too,

for your donations of yarn and put them to good use.

Come join us at our meetings on the first Tuesday of every month, 7:00 p.m. at the Diggins' home in Brookhaven. Can't come out but want to be a part of this ministry? You can knit or crochet at home.

Just call Dawn at 610.876.5011.



All Saints Sunday, Veterans Recognition

On November 7th, in a power point presentation we will remember those of the Church Family who have gone on to glory in the past year.

We will also ask the congregation if there are other loved ones who have passed. Each family present in worship will be presented with a rose in

remembrance of the "saints" passing into glory.

Veterans' Recognition: November 7th is also Veterans' Sunday. We will recognize our veterans for their services to our nation with a special gift of Psalm 91. We will read the names of all active servicemen and women in the

Church Family along with our veterans. Please be sure to call the church office (610.459.0248) with the names of your veterans and active military personnel to be honored.

Mark your calendar now. This is a Sunday you will want to be present in worship at the 8:15, 9:30 contemporary or 11:00 service.



ALL SAINTS' DAY

Operation Christmas Child

Looking for a fun family project? Operation Christmas Child is a great way to bring joy and the Good News of Jesus Christ to children around the world while also providing a good teaching moment for your children about showing compassion and sharing love to those in need of hope. Spend time with you children selecting

small items such as school supplies, toys, hygiene items, etc. and then pack them up in either an empty shoe box or a small plastic container and drop the filled box off at the church. Shoeboxes are available in the hall leading from the Narthex.

For more detailed information, please pick up a brochure on the literature table

in the back of the church. Attached to the brochure are the labels identifying if the box is for a girl or a boy and the age group, and an envelope to enclose a \$7.00 check to cover the cost of shipping.

The deadline for dropping of the boxes is Sunday, November 14th. Bring a smile to a child's face and be bless in the process.

Living Your Destiny by Graham Cooke

"All of the tests you presently face are there to develop you into the person you need to be to live your destiny. Everything you are going through has been

aligned by God to forge you into the person He has called you to be. **Your destiny is unfolding before your very eyes.** You have a battle to win, and He must prepare you

for it. When we embrace the idea that God has a plan for us, no issue should be able to stop us." Read the rest of the article at grahamcooke.com, May Newsletter.

Annual Christmas Cantata

"Only Love" by R. Vader and J. Rouse

The Span and scope of the Christmas Story is in stark contrast to the rather sparse information offered to us in the narrative of the New Testament. What we have is a timeless and mystifying mosaic of events that could never pass the scrutiny of human invention and imagination. It remains impossible to imagine the unthinkable. This is a story so profound that it demands to be

shrouded in simplicity—so breathtaking that it requires some space just to comprehend the intent, let alone the reality—so unbelievable that it must be anchored in truth. This is a story that is Divine in origin and Eternal in design. This is the story of God in Heaven Who loved the world so much that He sent His Son that whoever believes in Him and the sacrifice that He would make,

would never perish, but would have eternal life.

Only God could make that promise—only Christ could pay that price—"Only Love" could write this story.

Presented by the Sanctuary choir and Orchestra, Sunday, December 19, 2010 at the 8:00 and 11:00 a.m. worship services. Please note the time change of the early service.

Community
Thanksgiving
Service

Sunday,
7:00 p.m.

St. Timothy's
Lutheran Church
Pennell Road and
Lamppost Lane
Aston



Word of Hope

Children's Center News

Our November Bible Verse:
"Always give thanks."
Psalms 136:1

We are always thankful for many things here at the Children's Center. Working with wonderful women, teaching God's love for all, and the delightful children are His greatest gift to me.

We had a Phillies "pep rally" this morning that actually brought tears to my

eyes. The children learn to appreciate all of God's blessings, and of course the Pilgrims and the first Thanksgiving. The Pre-Kindergarten classes will be taking a trip to Tyler Arboretum to learn about the Lenape Indians.

Our fruit of the spirit this month is "Peace." Chapel will be on November 29th and November 30th at 9:30 a.m.

We have started Operation Christmas Child, and

our annual food drive starts November 1st and ends on November 19th. Parents participate with their children to teach the importance helping others and sharing. As always, I extend an invitation to see our pre-school. Have a blessed and bountiful Thanksgiving from all of us at the Children's Center.

Kris Leary
Director

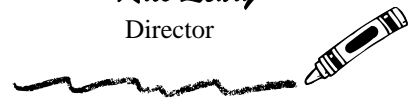

Notable Quotes

- * "Anything that you think you know about God that you can't find in the person of Jesus Christ, you have reason to question."
- * "You won't have to

watch what you say if you watch what you think."

- * "Many Christians miss out on God encounters because they are satisfied with good theology."

- * "Revelation from scripture must take us to an encounter with God or it will only serve to make us more religious."

Bill Johnson, Pastor
Bethel Church, Redding CA

A Feast of Thanksgiving (continued from the back page)

acknowledge God's faithfulness in the present and dependence upon Him for the future. Samples of the fall harvest were hung in each family's booth to represent God's present blessing as well as ceremonies and prayers offered for His continued provision for the following year.

The holiday lasted over a week. On the eighth and final day of the feast, the high priest of Israel, in a great processional made up of priests and tens of thousands of worshipers, descended from the Temple Mount to pause briefly at the Pool of Siloam. A pitcher was filled with water, and the procession continued via a different route back to the Temple Mount. Here, in the midst of great ceremony, the

high priest poured the water out of the pitcher onto the altar.

Since in Israel the rains normally stop in March, there is no rain for almost seven months! If God does not provide the "early" rains in October and November, there will be no spring crop, and famine is at the doorstep. This ceremony, then, was intended to invoke God's blessing on the nation by providing life-giving water.

It is in connection with the Feast of Tabernacles and this eighth day that the gospel of John records a fascinating event.

"In the last day (eighth day), that great day of the feast, Jesus stood and cried out, saying, If any man thirst, let him come unto me, and drink. He that believeth

on me, as the scripture hath said, out of his heart shall flow rivers of living water" (John 7:37-38).

The Son of God was saying in the clearest possible way that He alone was the source of life and blessing; that He could meet every need of the human heart.

So this Thanksgiving Day let us remember what God has done for us in the past. Remembering that He has provided a way of salvation for us, given us His Spirit and led us in ways of righteousness, and by His will sustained us materially and physically all to His glory. And let us take hope both now and forever that Jesus is living water that always satisfies. Thanks be to God.

Pastor Ealy

Angel Food Ministries



Don't forget to order your Angel Food! Log onto their web site or stop by the church for November's menu and to order your meals. See the calendar on page 7 for the order dates. Call 610.459.2521 if you would like to order a Thanksgiving Box to be given to a family in need.



Overcoming Offense *(continued from the first page)*

take offense will give you victory. If for no other reason, you should refuse to be offended so that you and your family can inherit the blessings of God.

Let us purpose not to offend anyone, and let us purpose not to take offense. Regardless of what others do, we must always forgive and walk on with God.

Jesus set the example for us when He hung on the cross. As life ebbed from His body and His blood flowed to the ground, Jesus said, *“Father, forgive them; for they know not what they do...”* (Luke 23:34)

So instead of being offended and trying to get even, let go of any offense that tries to get you off track. You can't set out to get even and receive God's blessings.

Allow the Holy Spirit to search the innermost parts of your heart. Say with the Psalmist David, *“Search me, O God, and know my heart; test me and know my anxious thoughts. See if there is any offensive way in me, and lead me in the way everlasting.”* (Psalm 139: 23, 24 NIV)

The Holy Spirit wants to work within us today—to remove any offense, unforgiveness, bitterness or resentment locked in our hearts, making us pure before God. Then we can walk in God's will, knowing that by obeying His Word, we shall receive His blessing!

David cried, “Against thee and thee only have I sinned.” Seems like a funny thing to say, Didn't David sin against Uriah when he had him killed? There's a much bigger picture. By His crucifixion, Jesus took all sin on Himself and forgave all sin of all people for all time. “All people” - that includes you and me. If He forgave the most heinous acts against Himself, never deserving a single one of them, how can we not also forgive? We violate the very heart of God when we hang onto unforgiveness.

Jesus made the point in the parable of the unjust servant who could not pay his unimaginably huge debt to his master. The master forgave him. The same servant then demanded a fellow slave repay what he was owed, and had him thrown into prison when he couldn't pay.

“For if you forgive people their trespasses [their reckless and willful sins, leaving them, letting them go, and giving up resentment], your heavenly Father will also forgive you.

“But if you do not forgive others their trespasses, neither will your Father forgive you your trespasses.” (Amp).

The parable concludes, “Then his master called him and said to him, You contemptible and wicked attendant! I forgave and cancelled all that [great] debt of yours because you begged me to. And should you not have had pity and mercy on your fellow attendant, as I had pity and mercy on you?”

“And in wrath his master turned him over to the torturers (the jailers), till he should pay all that he owed.

“So also My heavenly Fa-

ther will deal with every one of you if you do not freely forgive your brother from your heart his offenses.”

Jesus made very clear the premium He and the Father place on forgiveness. He told that parable in response to Peter's question, *“Lord, how many times may my brother sin against me and I forgive him and let it go? [As many as] up to seven times?”*

“Jesus answered him, *I tell you, not up to seven times, but seventy times seven!*” You can read about it in Matthew 18.

When we opt not to forgive, we stand against what is in the Father's heart. His intent of that work on the cross was accomplished: He reconciled us back to Him by His supreme act of forgiveness with a Love so deep it's hard to comprehend. It's His amazing Love that brought us right into the family of God. When we join our hearts with His and co-labor with Him to accomplish His purposes, we see Christ, *“the hope of glory,”* formed in us. (Colossians 1:27).

You've got His glory in you! Set your heart to release His glory in the earth (that's how scripture puts it; where you live qualifies!) by lavishly forgiving.

Remember how outrageously you are beloved by God your Father, and your brother Jesus. And Holy Spirit is fully committed to transforming you and empowering you to do and be all that God wants of you. Chose to spread love and forgiveness. It's in our DNA!

Pastor McGill

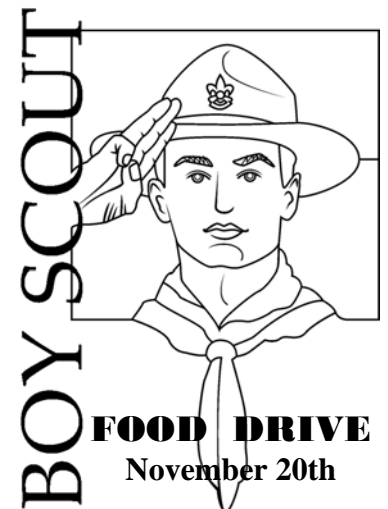
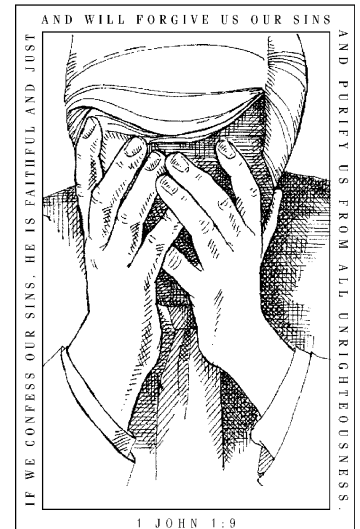

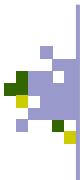

THANKSGIVING NAME CARDS

When you set your table this Thanksgiving, use these homemade name cards with a special message for each guest.

What you need:

- Index cards, any size (one per person)
- Markers
- Fall stickers (optional)
- Fall foam shapes (optional)

What you do:

1. List everyone who will be at your Thanksgiving dinner.
2. Fold each index card in half so it can stand.
3. On one side of each card, write a person's name.
4. Decorate around each name with markers, stickers or foam shapes.
5. On the blank side of each card, write a different Bible verse about blessings or giving thanks. Suggestions include 1 Chronicles 16:34; 1 Chronicles 29:13; Psalm 107:8; Psalm 118:21, 28; or 1 Thessalonians 5:18.
6. Another idea is to write one or more words from one verse on each person's card (depending on the number of guests and words). You can write the verse in order and have people read around the table, or you can mix up the words so guests have to put them in the correct order. (Remember to list the Scripture reference.)

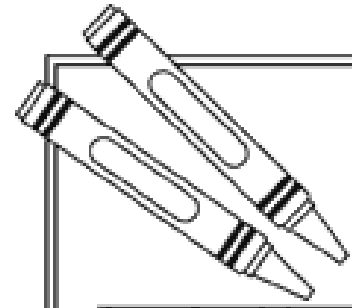

Just for KIDS

Multiply your thanks

We have so many reasons to give thanks to God. When we take time to count our blessings, we realize they just keep multiplying and adding up.

Use your multiplication or addition skills to answer each equation. Then use the word key below to write out Psalm 100:4 (NIV).

WORD KEY
 22= him 16= courts 4=gates 24=name 9=praise 8=and 2=to
 12= his 18= give 6= with 10= Enter 20= thanks 15= thanksgiving

"

$\frac{\quad}{5 \times 2 \text{ or } 5 + 5}$	$\frac{\quad}{12 \times 1 \text{ or } 7 + 5}$	$\frac{\quad}{2 \times 2 \text{ or } 3 + 1}$
$\frac{\quad}{6 \times 1 \text{ or } 5 + 1}$	$\frac{\quad}{3 \times 5 \text{ or } 5 + 5 + 5}$	$\frac{\quad}{4 \times 2 \text{ or } 6 + 2}$
$\frac{\quad}{6 \times 2 \text{ or } 6 + 6}$	$\frac{\quad}{8 \times 2 \text{ or } 8 + 8}$	$\frac{\quad}{3 \times 2 \text{ or } 3 + 3}$
$\frac{\quad}{3 \times 3 \text{ or } 3 + 3 + 3}$	$\frac{\quad}{9 \times 2 \text{ or } 9 + 9}$	$\frac{\quad}{10 \times 2 \text{ or } 10 + 10}$
$\frac{\quad}{1 \times 2 \text{ or } 1 + 1}$	$\frac{\quad}{11 \times 2 \text{ or } 16 + 6}$	$\frac{\quad}{8 \times 1 \text{ or } 3 + 5}$
$\frac{\quad}{9 \times 1 \text{ or } 5 + 4}$	$\frac{\quad}{3 \times 4 \text{ or } 4 + 4 + 4}$	$\frac{\quad}{8 \times 3 \text{ or } 8 + 8 + 8}$



"

Answer: "Enter his gates with thanksgiving and his courts with praise; give thanks to him and praise his name." (Psalm 100:4, NIV)



November 2010 Calendar of Events

This Update Printed: Wednesday, October 20, 2010

Sunday	Monday	Tuesday	Wednesday	Thursday	Friday	Saturday
	1 All Saints Day 7:15 PM Ark BS (Owsley) 7:30 PM Se lah Bible Study (Brownhill)	2 Election Day 9:00 AM Library Open 7:00 PM Kelli Girls BS (6) 7:00 PM Baptism Sem (L) 7:00 PM Prayer Shawl (Digging)	3 9:30 AM Staff Mtg (L) 1:30 PM Education (L) 6:30 PM 930 Reh (S) 7:00 PM Trustees (L) 7:00 PM Cantata Rehearsal (216) 7:00 PM Bells of Hope (104) 7:30 PM 20's Bible Study (6) 7:45 PM Sanctuary Choir (216)	4 1:00 PM Bible Study (L) 7:00 PM Charge Conference (HH)	5	6 Organ AGO (S) 8:00 AM HIS Ministry (HH)
<p>Every Sunday: 8:15, 9:30 & 11:00 a.m. Worship 9:30 a.m. – Sunday School for all ages</p>						
Operation Christmas Child collection						
7 All Saints Sunday Daylight Savings--set back 1 hour Blood Pressure Screening (HH) 9:00 AM Angel Food (HH) 9:15 AM-10:45 am. Library open 10:30 AM Angel Food (HH) 11:00 AM Children's Choir (101) 6:00 PM YF PULSE (HH, 6)	8 4:00 PM WOH Deadline (Ofc) 7:00 PM Men's Fellowship (L) 7:30 PM Fuzzie Slippers Girls Bbl Sdy (6)	9 9:00 AM Library Open 7:00 PM Ad Bd (HH)	10 9:30 AM Staff Mtg (L) 1:00 PM Angel Food order (HH) 5:30 PM Angel Food orders (HH) 6:30 PM 930 Reh (S) 7:00 PM Bells of Hope (104) 7:30 PM 20's Bible Study (6)	11 Veterans Day 11:00 AM Busy Beavers (Kit) 1:00 PM Bible Study (L) 7:00 PM Cantata Rehearsal (216) 7:45 PM Sanctuary Choir (216)	12	13 8:00 AM HIS Ministry (HH) 9:00 AM Annual Conference (Hempfield UMC)
Operation Christmas Child collection						
14 Communion 9:00 AM Angel Food (HH) 9:15 AM-10:45 am. Library open 10:30 AM Angel Food (HH) 11:00 AM Children's Choir (101) 6:00 PM YF PULSE (HH, 6)	15 7:15 PM Ark BS (Owsley) 7:30 PM Se lah Bible Study (Brownhill)	16 9:00 AM MHCC Cookie Bake (Kit) 9:00 AM Library Open 7:00 PM Kelli Girls BS (6) 7:00 PM SPR (L)	17 9:30 AM Staff Mtg (L) 6:30 PM 930 Reh (S) 7:00 PM Bells of Hope (104) 7:30 PM 20's Bible Study (6)	18 8:30 AM WOH Mailing (HH) 1:00 PM Bible Study (L) 7:00 PM Cantata Rehearsal (216) 7:45 PM Sanctuary Choir (216)	19	20 9:00 AM Angel Food pick-up (HH)
Operation Christmas Child collection						
21 Harvest Home Volunteer Appreciation 9:15 AM-10:45 am. Library open 11:00 AM Children's Choir (101) 6:00 PM YF PULSE (HH, 6) 7:00 PM Community Thanksgiving Serv (St Tim Lutheran)	22 7:00 PM Men's Fellowship (L) 7:30 PM Fuzzie Slippers Girls Bbl Sdy (6)	23 9:00 AM Library Open 7:00 PM Worship Com (L)	24 9:30 AM Staff Mtg (L) 6:30 PM 930 Reh (S) 7:00 PM Bells of Hope (104) 7:30 PM 20's Bible Study (6)	25 Thanksgiving Office Closed 	26	27
				MHCC Closed		
28 Advent 1st Sunday Baptism UM Student Day 9:15 AM-10:45 am. Library open 11:00 AM Children's Choir (101) 	29	30 9:00 AM Library Open	<p>Community Events: Sundays— 5:30 p.m. Cub Den 5 (103) 6:00 p.m. Cub Den 4 (101) Monday—7:00 p.m. Boy Scout Trp 292 (FH) Tuesdays – 8:00 pm AA (FH) Thursdays – 6:00 pm AA (FH) 3rd Friday – 6:30 pm Pack 77 meetings (FH)</p>			



***"Blessing and glory and
wisdom and thanksgiving and
honor and power and might
be to our God
forever and ever! Amen."***

Revelation 7:12, NRSV

A Feast of Thanksgiving

When we think about the origins of our American Thanksgiving, our minds perhaps turn to images of Pilgrims and Native Americans or perhaps of Abraham Lincoln who pronounced the first official holiday. It is a day we have set aside to be thankful for what we have been given. As Christians our thanks is lifted up to our Creator and Sustainer, God Almighty.

Historically, the Old Testament also had a time of Thanksgiving. God had declared to the nation of Israel that once a year they were to gather for a time of reflection and thankfulness. This celebration was called the Feast of Tabernacles, Booths or simply

"The Feast" because it was known so well. It is mentioned in Leviticus 23:39 and speaks of the day when the Son of God will tabernacle (or dwell) among men, wipe away every tear and bring into fruition the Kingdom of God.

In the Jewish calendar year this feast was one of the four required events that every adult male was obliged to attend which included a pilgrimage to Jerusalem. But it was unique in that this feast included a person's entire family, servants and all. Participants constructed a hut or booth made from branches of the local trees to be their dwelling place for over a week. Israelites were reenact-

ing the nation's time of desert wondering before entering the Promised Land. The purpose of the booth was that it was a symbol of protection, preservation and shelter all of which came from God. It was a time to remember the provision and guidance that was afforded the nation during those 40 years in the desert. Remember the Israelites shoes did not wear out, they were provided with food (manna, quail) and a pillar of fire or smoke guided them for their entire experience.

Not only were the Israelites to remember what God had done for the nation in the past, but they were also to

(continued on Page 4)